



TNC 128

The Compact Straight-Cut Control for Milling, Drilling and Boring Machines

www.heidenhain.com/cnc-controls



This brochure describes the functions and specifications of the TNC 128 with NC software 771841-18.

The TNC 128...

Where can it be used?	Compact and convenient The control for simple milling, drilling and boring machines	4
What does it look like?	Intuitive and user-friendly The TNC 128 in dialog with the user	6
What can it do?	Minimize setup and non-machining time The TNC 128 makes setup easy	8
How is it programmed?	Programming, editing and testing A full range of possibilities with the TNC 128 Graphical support in any scenario	10
	Programming on the shop floor Practical cycles for recurring operations Reusing programmed contour elements Rapid availability of all information	12
	Open to outside information Fast data transfer with the TNC 128	16
What accessories are there?	Positioning with an electronic handwheel Fine motion control of axes	17
	Workpiece measurement Setup, preset setting and measuring with touch trigger probes	18
	Tool measurement Measuring length, radius and wear inside the machine	19
... At a glance	Overview User functions Software options and accessories Specifications	20

Compact and convenient

The control for simple milling, drilling and boring machines

Controls from HEIDENHAIN have been proving their reliability on various types of machines for over 45 years. In the early days of CNC machining, most operations were performed with simple CNC milling machines that were capable of cutting with no more than three servo-controlled axes at only moderate traversing speeds. Nowadays complex machining centers are in operation, CNC machines are linked together, and machine tools are equipped with automated loading systems. Less complex operations continue to be performed on simple CNC milling machines. The TNC 128 straight-cut control was conceived for exactly this purpose. Its scope of functions is perfectly tailored to simple CNC machines, and it is suitable for machines with central drive as well as those with independent drive.

Shop-oriented programming

Shop-oriented programming is an important attribute of the TNC 128, particularly since the TNC controls are rooted in the shop floor.

In the past years, machining processes have become more complex, and the machines themselves more powerful. Throughout, the fundamental operating concept of the TNC controls has remained the same despite their continued development and improvement.

The proven operation is also the basis for the user-friendly programming of the TNC 128, since it assists you during program creation with help graphics, practical prompts, fixed cycles, and cycles for coordinate transformation.

Easy to operate

For simple work, such as face milling, you need not write a program on the TNC 128. That's because it makes manual control equally easy—either by means of the axis keys or, for maximum sensitivity, with an electronic handwheel.

Offline programming

The TNC 128 is easy to program remotely as well. Its Gigabit Ethernet interface ensures extremely short upload times, even for long programs.

The TNC 128 is compact and easy to read

The TNC 128 is a compact but versatile straight-cut control for three servo axes and servo spindle. A further servo axis is an option. Thanks to its user-friendly operation and scope of features, it is especially well suited for use on universal milling, drilling and boring machines for the following possibilities:

- Series and single-part production
- Machine building
- Prototypes and pilot plants
- Repair departments
- Training and education facilities

It also offers the applicable features both necessary and helpful for:

Universal milling machines

- Milling cycles for rectangular pockets, rectangular studs, and face milling
- Rapid preset setting with HEIDENHAIN touch probes

Drilling and boring machines

- Drilling and boring cycles
- Cycles for circular and linear point patterns

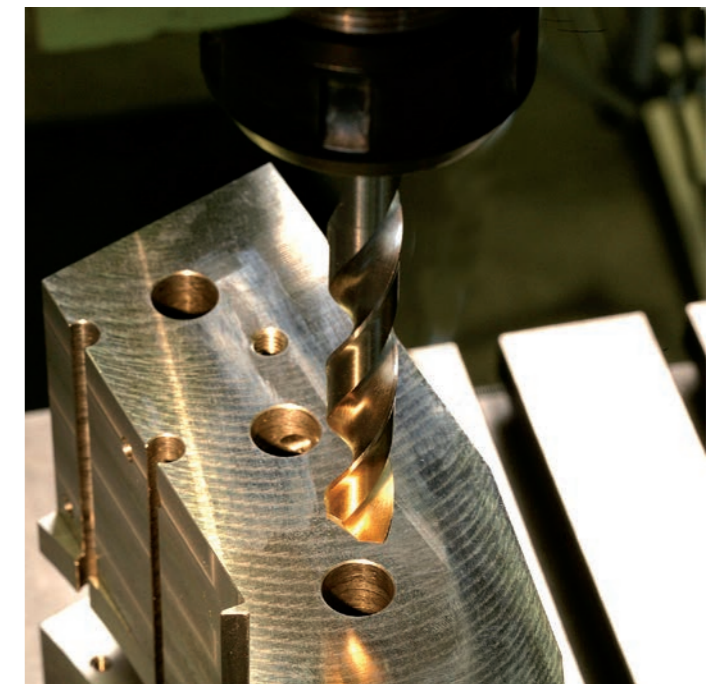
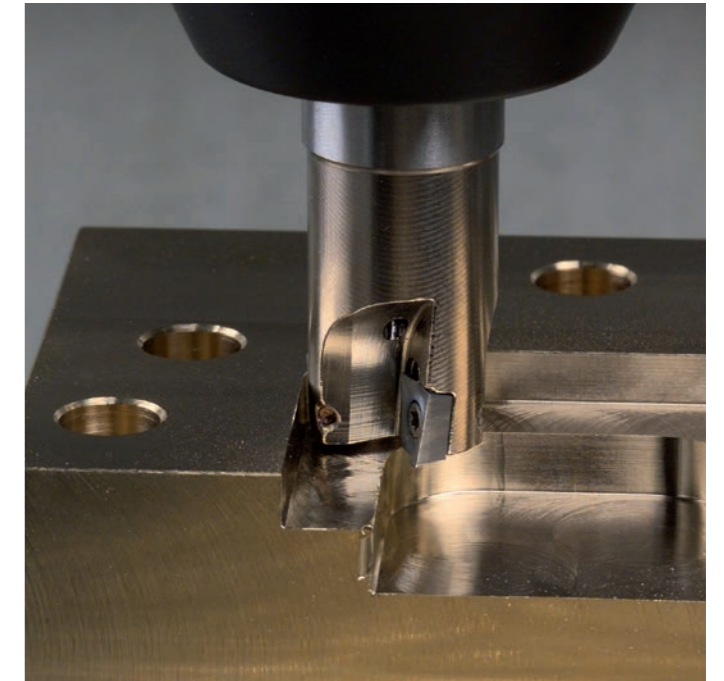

Intuitive and user-friendly

The TNC 128 in dialog with the user

The screen

In a clear format, the 12.1-inch TFT color flat screen displays all of the information you need for programming, operating, and checking the control and the machine, including program blocks, tips, and error messages. More information is provided through graphic support during program entry, test run, and actual machining.

You can also use a split screen to display your NC blocks on one side and the graphical image or the status display on the other.

While the program is running, status displays are available that inform you about the tool position, current program, active cycles, coordinate transformations, and more. The TNC 128 even displays the current machining time.

The operating panel

Like all of the TNCs from HEIDENHAIN, the operating panel was designed with the programming process in mind. Program entry is aided by the thoughtful arrangement of keys. Readily understood symbols and abbreviations unmistakably identify the various functions. Certain functions of the TNC 128 are available by soft key.

The integrated machine operating panel features readily exchangeable snap-on keys permitting easy adaptation to the given machine configuration. With the override potentiometers, you can make fine adjustments to the feed rate, rapid traverse, and spindle speed.

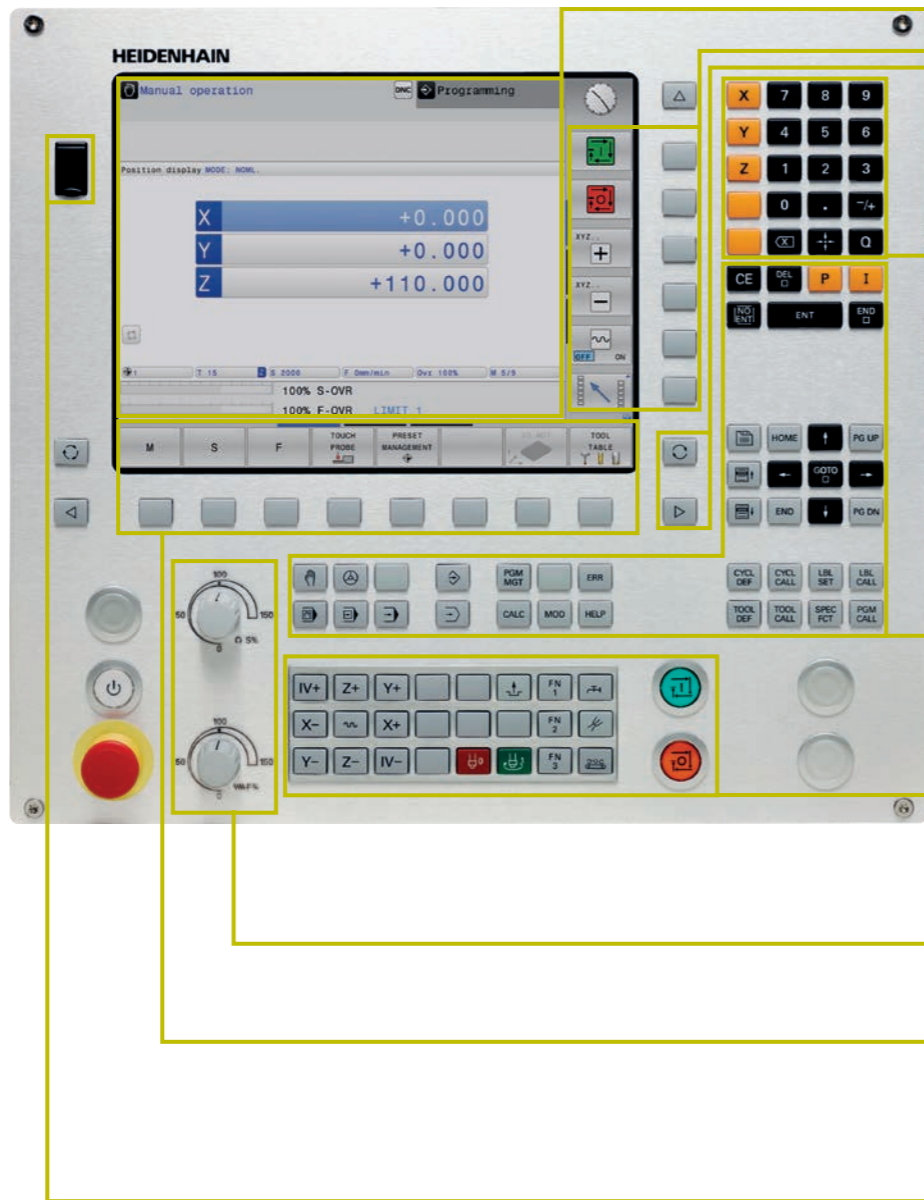

The screen content includes two operating modes, the program, graphics, and the machine status

PLC function keys (soft keys) for machine functions

Keys for **screen management** (screen layout), operating mode, and switching between soft-key rows

Axis-selection keys and **numeric keypad**

Function keys for programming modes, machine operating modes, TNC functions, management, and navigation

Machine operating panel with snap-on keys

Override potentiometers for feed rate, rapid traverse, and spindle speed

Self-explanatory **function keys** (soft keys) for NC programming

USB port for additional data storage or other pointing devices

Ergonomic and elegant, state-of-the-art and field-proven—controls from HEIDENHAIN in a modern design. Judge for yourself:

Durable

The high-quality stainless-steel design of the TNC 128 features a special protective coating, making it particularly resistant to contamination and wear.

Smooth

The rectangular, slightly rounded keys are pleasant to the touch and reliable in operation. Their abrasion-resistant labeling can withstand extreme shop conditions.

Versatile

Soft keys for both programming and machine functions always show only the currently available selections.

Sensitive

With the handy control knobs, you can make fine adjustments to the feed rate and spindle speed.

Communicative

The fast USB 2.0 interface lets you connect storage media or pointing devices to the operating panel simply and directly.

Flexible

The integrated machine operating panel features easily exchangeable snap-on keys.

Reliable

The elevated key bed of the machine operating panel prevents accidental actuation.

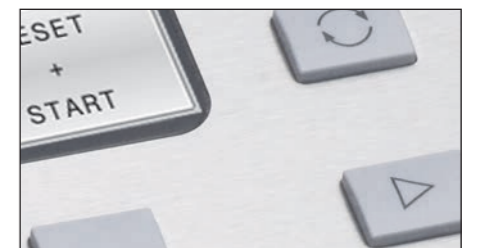

Minimize setup and non-machining time

The TNC 128 makes setup easy

Before machining can begin, the workpiece must first be clamped, the machine must be set up, the position of the workpiece in the machine must be determined, and the preset must be set. Without support from the control, this is often a time-consuming but indispensable procedure because any error directly reduces the machining accuracy. Particularly in small and medium-sized production runs, as well as in the case of very large workpieces, setup times become a significant factor.

Here the TNC 128 shows its strengths: with its practice-oriented setup features it assists the user and helps to reduce non-machining time. In conjunction with the touch probes, the TNC 128 offers numerous probing functions for setting the preset as well as measuring the workpieces and tools.

Fine manual axis control

During setup, you can use the axis-direction keys to move the machine axes manually or with an incremental jog. A simpler and more reliable way, however, is to use the electronic handwheels from HEIDENHAIN (see page 17). With these handwheels, you are always close to the action, enjoy a close-up view of the setup process, and can control the infeed responsively and precisely.

Adapting the probing speed

In many cases, the workpiece must be probed at unseen positions or in cramped spaces, and the standard probing feed rate is usually too fast for this. In such situations you can use the feed rate potentiometer to change the feed rate during probing without affecting the accuracy.

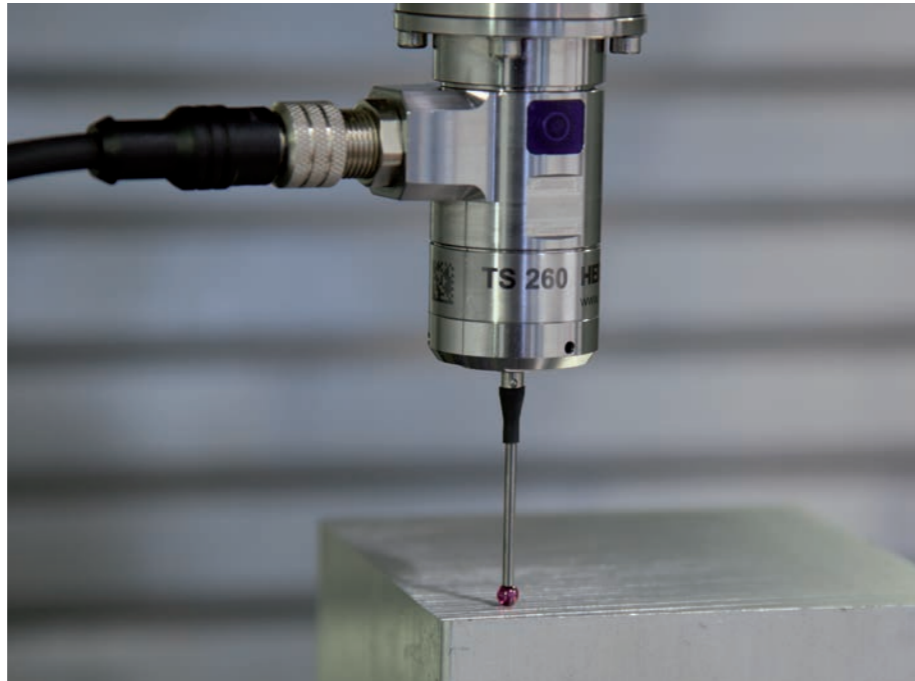

Setting presets

A preset allows you to assign a defined value displayed by the TNC to any position on the workpiece. Finding this point quickly and reliably reduces non-productive time and increases machining accuracy.

The TNC 128 features probing functions for setting presets. Ascertained presets can be saved as follows:

- Using the preset management
- In a datum table
- Through direct setting of the display

Preset management with the preset table

Preset management enables flexible machining, shorter setup times, and higher throughput. In other words, setting up your machine is greatly simplified.

In preset management, you can save any number of presets. In order to permanently save fixed presets in the machine's workspace, you can also write-protect individual lines. There are two possibilities for rapidly saving the presets:

- Via a soft key in Manual mode
- Via the probing functions

Tool measurement and automatic compensation of tool data

Together with the TT 160 for tool measurement (see page 19), the TNC 128 makes it possible to measure tools while they are in the machine spindle. The TNC 128 then stores the determined values, such as tool length and radius, in its tool memory. By inspecting the tool, you can quickly detect wear or breakage for preventing scrap and rework.

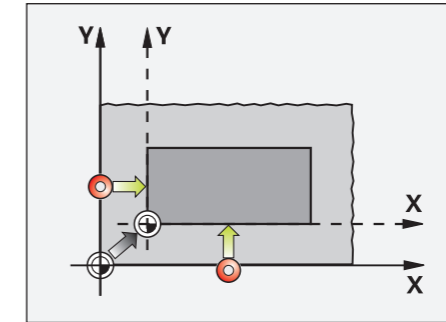

Setting a preset on a corner, for example, or in the center of a circular stud

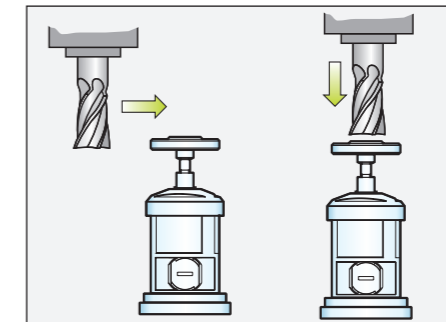
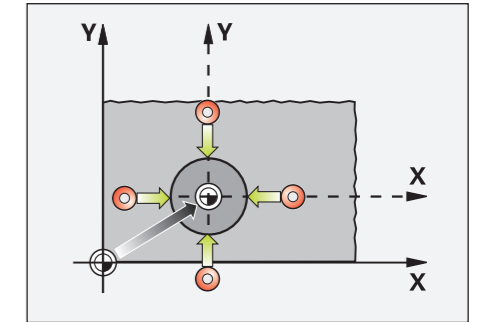

Tool length and radius measurement

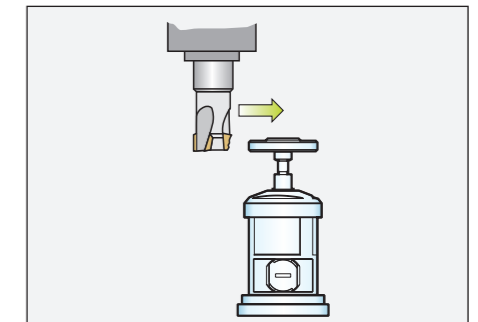

Measuring tool wear

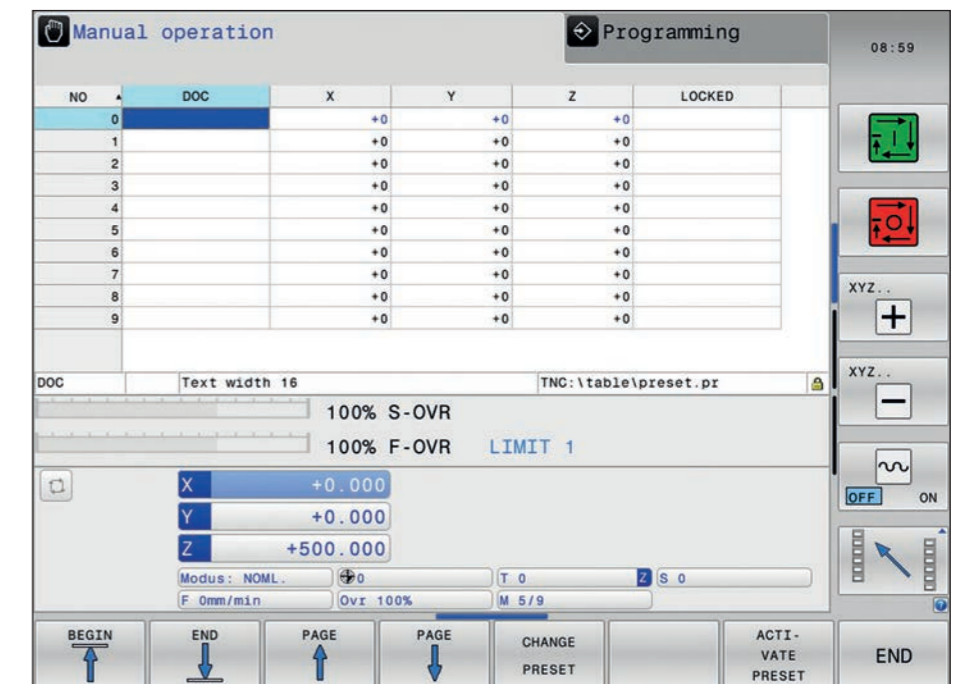

Programming, editing, testing

A full range of possibilities with the TNC 128

Graphical support in any scenario

Besides being universally deployable, the TNC 128 is equally flexible when it comes to programming and machining.

Positioning with Manual Data Input

You don't need to create a complete program in order to start machining with the TNC 128. You can machine a workpiece step by step using both manual machining and automatic positioning in any sequence.

Programming at the machine

HEIDENHAIN controls are designed for shop-friendly programming right at the machine. Instead of requiring you to know G codes, the Klartext conversational programming language provides its own buttons and soft keys, which precisely indicate the respectively associated function. You initiate a HEIDENHAIN Klartext dialog with a keystroke and the TNC immediately begins to support you actively in your work. Unambiguous questions and prompts help you enter all the required information.

All interface texts, including Klartext tips, dialog prompting, program steps, and soft keys, are available in numerous languages.

Managing programs offline

The TNC 128 is also well equipped for external access. Its interfaces allow the control to be integrated into networks in order to connect with programming stations or other data storage media.



Programming graphics

The two-dimensional programming graphics give you additional assurance: while you are programming, the TNC 128 renders every programmed movement on the screen. You can opt for a plan view, side view, or front view.

Program verification graphics

For added certainty prior to machining, the TNC 128 can graphically simulate the machining of the workpiece. This simulation can be viewed in different formats:

- Plan view at different levels of depth
- Three projections (as in the workpiece drawing)
- 3D view

Details can be displayed at magnification. The TNC 128 also displays the calculated machining time in hours, minutes, and seconds. The 3D view of the TNC provides a measuring function. When you move the mouse pointer anywhere within the image, the coordinates of that position are displayed.

Program-run graphics

The program-run graphics display the workpiece in real time in order to show you the machining progress. Direct observation of the workpiece is usually impossible due to coolant and the safety enclosure. During machining, you can switch between various operating modes at any time in order to create programs, for example. And at the press of a button, you can cast a glance at the machining progress while programming.

Help graphics

During cycle programming in Klartext, the TNC shows a separate illustration for each parameter. This makes it easier to understand the function and accelerates programming.

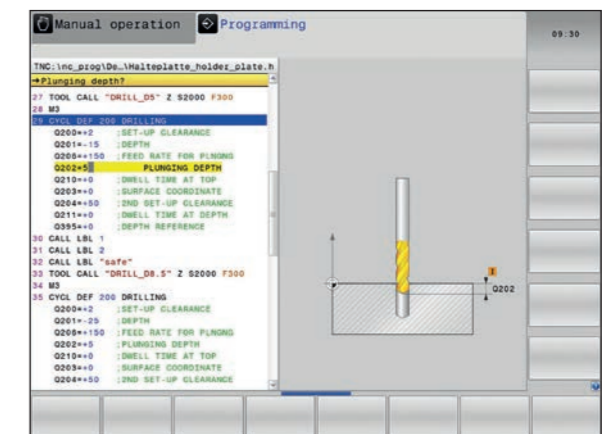
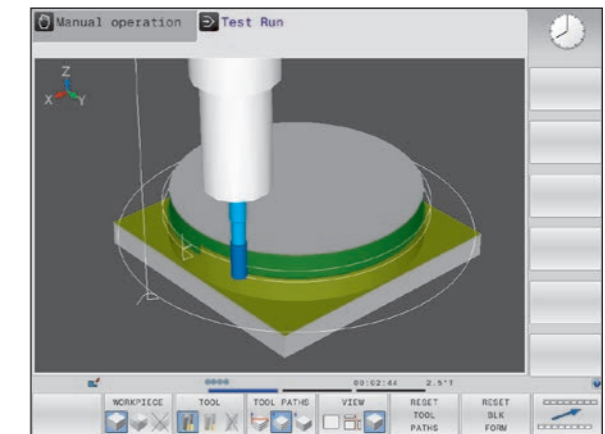
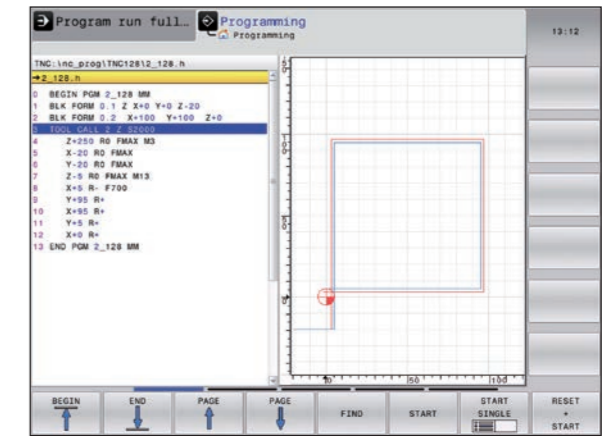

Programming on the shop floor

Practical cycles for recurring operations

Fixed cycles for milling, drilling and boring

Frequently recurring operations consisting of multiple machining steps are stored as cycles in the TNC 128. Dialog guidance and help graphics illustrating the required input parameters assist you in programming them.

Standard cycles

In addition to the fixed cycles for drilling, tapping (with or without floating tap holder), face milling, rectangular pockets, rectangular studs, reaming, and boring, there are also cycles for hole patterns and milling.

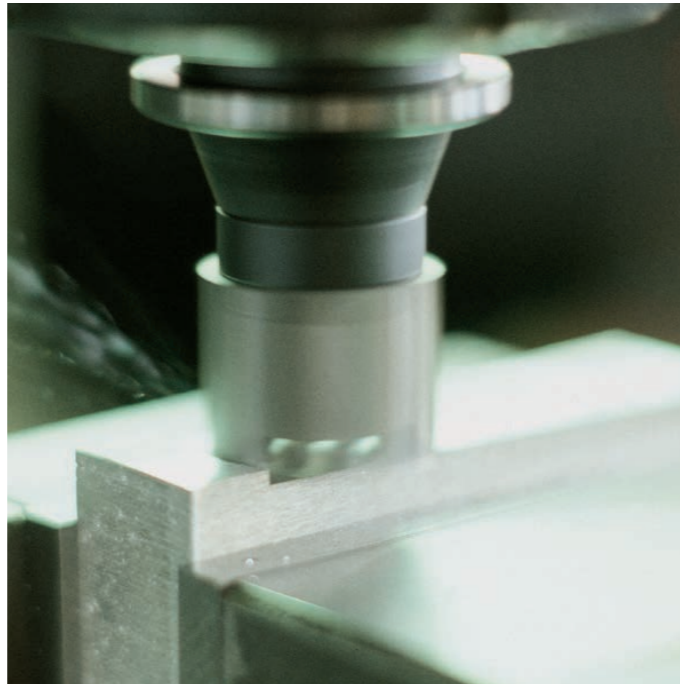

OEM cycles

Machine manufacturers can incorporate their specialized production expertise in the form of additional fixed cycles and store them in the TNC 128. The end user can write his own cycles as well. HEIDENHAIN makes this possible with its PC software CycleDesign, which allows you to create input parameters and arrange the TNC 128's soft key structure as desired.

Machining with parametric programming

Parametric programming also offers you a simple method of realizing operations for which no standard cycle is available. At your disposal are basic arithmetical operations, trigonometric functions, roots, powers, logarithmic functions, parentheses, and logical comparisons with conditional jump instructions.

Programming machining patterns with ease and flexibility

Positions to be machined are often arranged in patterns on the workpiece. The TNC 128's graphical support helps you program a wide range of machining patterns with ease and exceptional flexibility. You can define as many point patterns as desired with various numbers of points. During machining, you can then have all of the points executed as a unit, or each point individually.

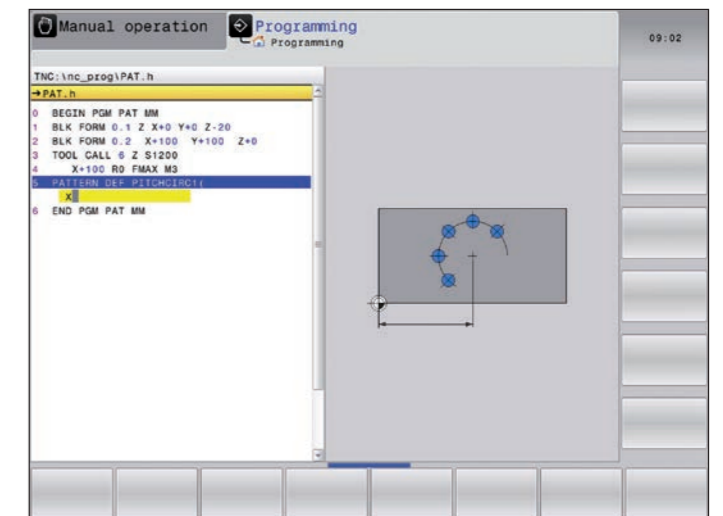

Programming on the shop floor

Reusing programmed contour elements

Coordinate transformations

If you need a pre-programmed contour at different locations and in different sizes on the workpiece, then the TNC 128 offers you a convenient solution in the form of coordinate transformations.

With coordinate transformation you can, for example, **mirror** the coordinate system or shift the datum. With a scaling factor you can enlarge or reduce contours to respect shrinkage or oversizes.

Program-section repeats and subprograms

Many machining operations repeat themselves either on the same workpiece or on different workpieces. Once you have programmed a detail, there is no need to program it again. With its subprogram technology, the TNC can save you a great deal of programming time.

In program-section repeats, you can label a section of the program, and the TNC will repeat this section as many times as required.

You can mark a program section as a subprogram and then call it at any point in the program and as often as you want.

With the program call function, you can even use a completely separate program at any location in your current program. This allows you to leverage already programmed and frequently required working steps or contours.

Of course you can also combine these programming techniques.

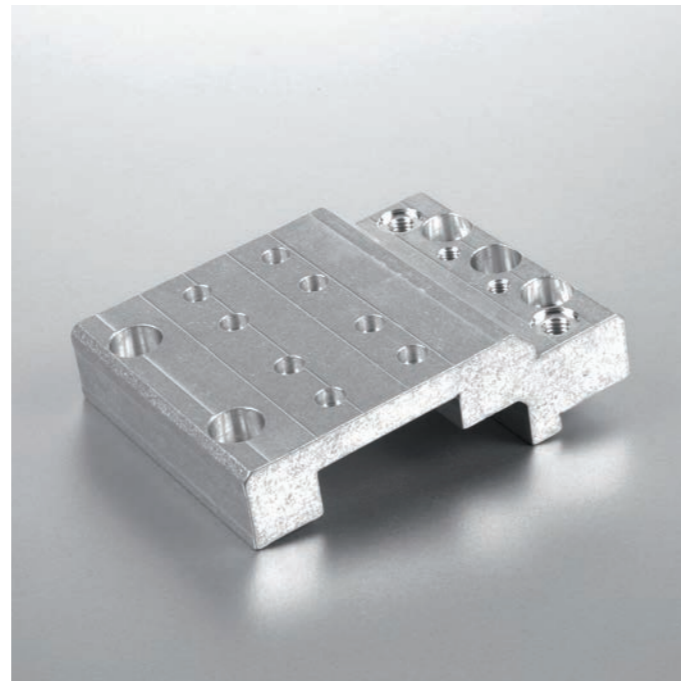
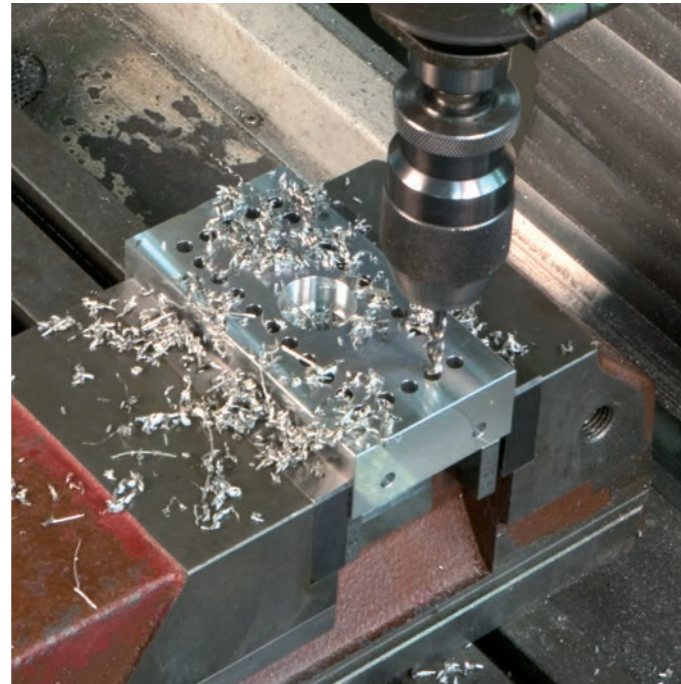

Rapid availability of all information

Do you have questions about a programming step, but your User's Manual is not at hand? No problem: the TNC 128 now features TNCguide, a convenient help system that displays the user documentation in a separate window.

You can activate TNCguide simply by pressing the HELP key on the TNC keyboard or by clicking any soft key when the mouse pointer has switched to a question mark. This is easily done by clicking the help icon permanently displayed on the TNC screen.

TNCguide generally displays the information instantaneously and in the correct context (context-sensitive help), immediately giving you the information you currently need. This function is particularly helpful for soft keys and provides a detailed explanation of their effects.

You can download the documentation in the desired language free of charge from the HEIDENHAIN website and save it to the appropriate language directory of the TNC's memory medium.

CAD Viewer (standard)

With the integrated CAD Viewer, you can open 3D CAD models and drawings directly on the TNC 128. This powerful viewer is a simple and simultaneously efficient solution for displaying CAD design data on the shop floor. Various view options as well as rotation and zoom capabilities allow detailed visual inspection and analysis of your CAD data.

You can also use the viewer to ascertain position values and dimensions from a 3D model. And you can set the preset as desired and select elements in the model. CAD Viewer shows the coordinates of the selected elements in a window.

The TNC 128 can depict the following file formats:

- STEP files (.STP and .STEP)
- IGES files (.IGS and .IGES)
- DXF files (.DXF)
- STL files

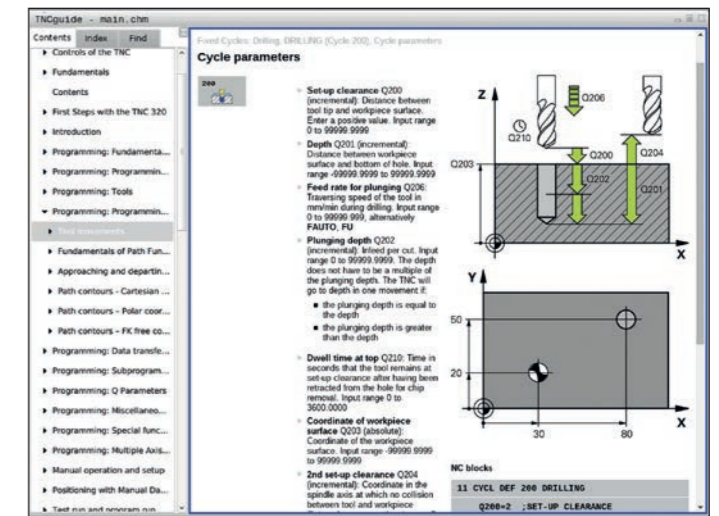
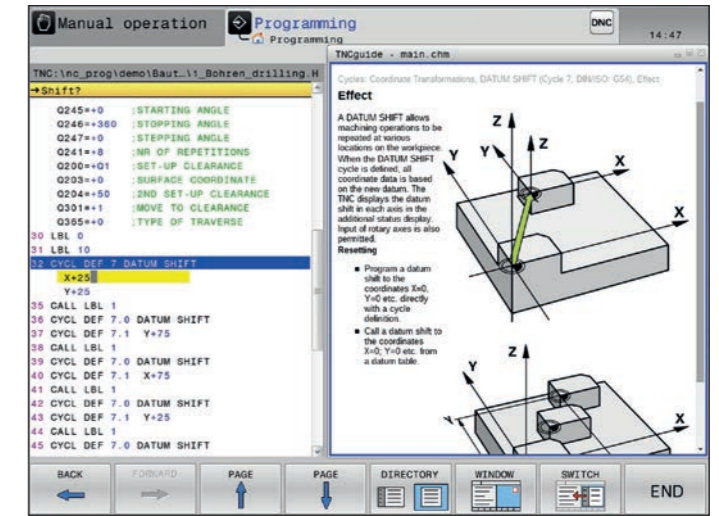

Open for communication

Fast data transfer with the TNC

Archiving programs

For well-organized program management on your control, simply place the individual files in directories (folders). You can structure the respective directories through individual subdirectories.

The exchange of programs and data archiving have become a matter of course in modern production. If there is a production bottleneck on a machine, the program can simply be run on a machine with sufficient capacity available. No matter whether job orders repeat themselves, similar parts need to be produced, or reworking is necessary during repairs, the appropriate program is always at hand.

With the TNC 128, you are ideally prepared for such demands, since the control is easily connected to a PC or integrated in your network. Even in its standard version, the TNC 128 features a Gigabit Ethernet interface in addition to its RS-232-C/V.24 data interface.

USB interface

The TNC 128 also supports standard memory media with USB interface. You can use USB memory media to quickly and easily save programs and tool data, and exchange these with PCs or other machines.

Programs for data transfer

With the aid of the free PC software TNCremo from HEIDENHAIN, you can do the following (including over the Ethernet interface):

- Transfer remotely stored part programs and tool tables in both directions
- Make backups

With the powerful TNCremoPlus PC software, you can also transfer the screen contents from the control to your PC using the live-screen function.



Positioning with an electronic handwheel

Fine motion control of axes

You can set up the workpiece by manually jogging the axes with the axis direction keys, but this task is easier and more finely controllable with the electronic handwheels from HEIDENHAIN.

In this method, the axis slides are moved by the feed motor in accordance with the handwheel's rotation. For particularly high sensitivity, you can incrementally set the amount of traversing distance for each handwheel rotation.

Panel-mounted handwheels

The HR 130 panel-mounted handwheel from HEIDENHAIN can be integrated into the machine operating panel or mounted to a different part of the machine.

Portable handwheels

The HR 510, HR 520, and HR 550 portable handwheels are particularly helpful when you work in close proximity to the machine's workspace. The axis keys and certain function keys are integrated into the housing. This lets you set up the machine or switch between the axes you want to move from wherever you happen to be standing with the handwheel. The HR 520 and HR 550 handwheels feature an integrated display for user-friendly remote operation of the control. As a wireless handwheel, the HR 550 is ideal for use on large machines. If you no longer need the handwheel, simply attach it to the machine using its built-in magnets.

Expanded range of functions of the HR 520 and HR 550

- Definable traversing distance per revolution
- Display for operating mode, actual position value, programmed feed rate, spindle speed, and error messages
- Override potentiometers for feed rate and spindle speed
- Selection of axes by means of keys and soft keys
- Keys for continuous traverse of the axes
- Emergency stop button
- Actual position capture
- NC Start/Stop
- Spindle on/off
- Soft keys for machine functions defined by the machine manufacturer



Workpiece measurement

Setup, preset setting and measuring with touch trigger probes

Workpiece touch probes* from HEIDENHAIN help you keep costs down: when used in conjunction with the TNC 128's probing cycles, they enable the execution of setup, measurement and inspection functions.

Upon contact with the workpiece surface, the stylus of a TS touch trigger probe is deflected. In that instant, the TS generates a triggering signal that is transmitted by cable to the control.

The touch probes are inserted directly into the machine tool spindle and can be equipped with various taper shanks depending on the machine. The ball tips, which are made of ruby, are available in different diameters with various stylus lengths.

The TNC 128 primarily uses touch probes with signal transmission by cable for machines with manual tool change:
TS 260
KT 130

* The touch probes must be interfaced to the TNC 128 by the machine manufacturer.



TS 260

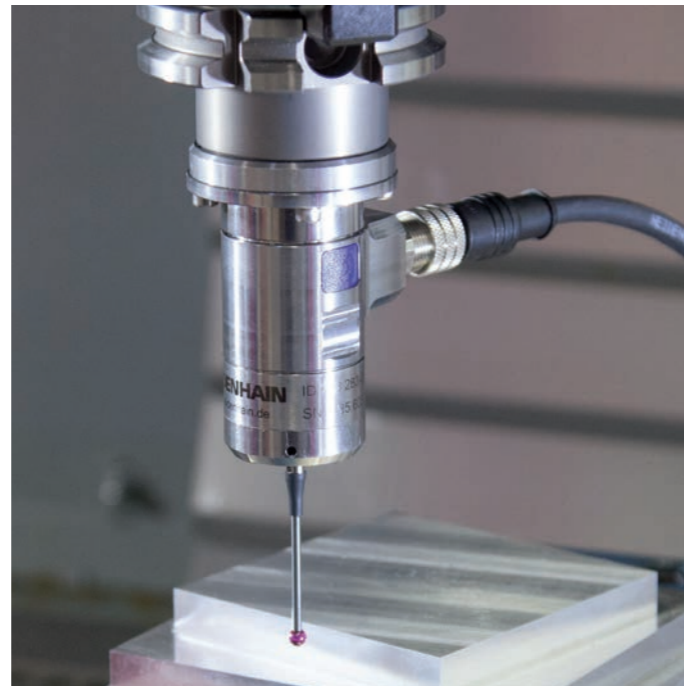

KT 130



More information about workpiece touch probes is available on the Internet at www.heidenhain.com or in the *Touch Probes – New Generation* Product Overview document.

Tool measurement

Measuring length, radius and wear inside the machine

A key factor in obtaining consistently high production quality is, of course, the tool itself. This requires exact measurement of the tool dimensions and periodic inspection of the tool for breakage, wear, and tooth shape. A suitable tool touch probe for tool measurement is the TT 160*. This touch probe is installed directly within the machine's workspace, where it enables tool measurement either before machining or during interruptions.

The TT 160 tool touch probe measures the tool length and radius. During probing of the rotating or stationary tool, such as for individual tooth measurement, the contact plate is deflected and a trigger signal is transmitted directly to the TNC 128.

* The touch probe must be interfaced to the TNC 128 by the machine manufacturer.



TT 160

More information about tool touch probes is available on the Internet at www.heidenhain.com or in the *Touch Probes – New Generation* Product Overview document.

Overview

User functions

User functions	Standard	Option	
Short description	✓	0 1	Basic version: 3 axes plus closed-loop spindle 1st additional axis for 4 axes plus open-loop or closed-loop spindle 2nd additional axis for 5 axes and open-loop spindle
Program entry	✓		HEIDENHAIN Klartext
Position feedback	✓ ✓ ✓		Nominal positions for straight lines in Cartesian coordinates Incremental or absolute dimensions Display and entry in mm or inches
Tool tables	✓		Multiple tool tables with any number of tools
Cutting data	✓		Automatic calculation of spindle speed, cutting speed, feed per tooth, and feed per revolution
Program jumps	✓ ✓ ✓		Subprograms Program-section repeat Any program as a subprogram
Fixed cycles	✓ ✓ ✓ ✓ ✓		Cycles for drilling, peck drilling, reaming, boring, counterboring, conventional and rigid tapping Clearing of level surfaces Rectangular pockets, slot milling, rectangular studs Point patterns on a circle and lines OEM cycles (special cycles developed by the machine manufacturer) can be integrated
Coordinate transformation	✓		Shifting, mirroring, scaling (axis-specific)
Q parameters Programming with variables	✓ ✓ ✓ ✓ ✓		Mathematical functions =, +, -, *, /, $\sin \alpha$, $\cos \alpha$, angle α of $\sin \alpha$ and $\cos \alpha$, $\tan \alpha$, arc sin, arc cos, arc tan, a^n , e^n , ln, log, \sqrt{a} , $\sqrt{a^2 + b^2}$ Logical operations (=, =/, <, >) Calculating with parentheses Absolute value of a number, constant π , negation, truncation of digits before or after the decimal point Functions for calculation of circles
Programming aids	✓ ✓ ✓ ✓ ✓ ✓		Calculator Complete list of all current error messages Context-sensitive help function for error messages TNCguide: the integrated help system; user information available directly on the TNC 128 Graphical support for the programming of cycles Comment and structure blocks in the NC program
Teach-in	✓		Application of actual positions directly in the NC program

User functions	Standard	Option	
Program verification graphics Display modes	✓ ✓ ✓		Graphical simulation of the machining operation, even while another program is being executed Plan view / projection in three planes / 3D view / 3D line graphics Detail enlargement
Programming graphics	✓		Rendering (2D graphics) of entered NC blocks in Programming and Editing mode, even while another program is being executed
Program-run graphics Display modes	✓ ✓		Real-time graphical simulation during execution of the program Plan view / view in three planes / 3D view
Machining time	✓ ✓		Calculation of machining time in the Test Run mode of operation Display of the current machining time in the Program Run operating modes
Returning to the contour	✓ ✓		Mid-program startup at any block in the program and movement to the calculated nominal position or continuation of the machining operation Program interruption, contour departure and return
Preset management	✓		For storing any presets
Datum tables	✓		Multiple datum tables for storing workpiece-specific datums
Touch probe cycles	✓ ✓		Touch probe calibration Preset setting
Conversational languages	✓		English, German, Czech, French, Italian, Spanish, Portuguese, Swedish, Danish, Finnish, Dutch, Polish, Hungarian, Russian (Cyrillic), Chinese (traditional, simplified), Slovenian, Slovak, Norwegian, Korean, Turkish, Romanian
CAD viewer	✓		Display of CAD models on the TNC

Overview

Software options and accessories

Option number	Option	With NC software 771841-xx or later	ID	Comment
01	Additional Axis	01	354540-01 353904-01	<ul style="list-style-type: none"> Additional control loop 1 Additional control loop 2
17	Touch Probe Functions	01	634063-01	Touch probe cycles <ul style="list-style-type: none"> Preset setting Tool measurement Touch probe input enabled for non-HEIDENHAIN touch probes
18	HEIDENHAIN DNC	01	526451-01	Communication with external Windows applications over COM component
46	Python OEM Process	01	579650-01	Python application on the TNC

Specifications

Specifications	
Components	<ul style="list-style-type: none"> Main computer with TNC keyboard and integrated 12.1-inch flat-panel display with soft keys
Operating system	<ul style="list-style-type: none"> HEROS real-time operating system for machine control
Memory	<ul style="list-style-type: none"> 1.8 GB (on CFR compact flash memory card)
Input resolution and display step	<ul style="list-style-type: none"> Linear axes: down to 0.1 μm Rotary axes: down to 0.0001°
Block processing time	<ul style="list-style-type: none"> 6 ms
Axis feedback control	<ul style="list-style-type: none"> Position-loop resolution: signal period of the position encoder/1024 Position controller cycle time: 3 ms
Error compensation	<ul style="list-style-type: none"> Linear and nonlinear axis error, backlash, thermal expansion, reversal error Static friction, sliding friction
Data interfaces	<ul style="list-style-type: none"> Network interface for remote operation of the TNC using the TNCremo or TNCremoPlus software from HEIDENHAIN 2 x Ethernet interface, 1 Gigabit USB 3.0 (and one USB 2.0 on the operating panel); the number of ports depends on the hardware used
Diagnostics	<ul style="list-style-type: none"> Fast and simple troubleshooting through integrated diagnostic aids
Ambient temperature	<ul style="list-style-type: none"> Operation: +5 °C to +40 °C Storage: -20 °C to +60 °C

Accessories	
Electronic handwheels	<ul style="list-style-type: none"> HR 510 FS portable handwheel, or HR 520 FS portable handwheel with display, or HR 550 FS portable wireless handwheel with display, or HR 130 panel-mounted handwheel
Workpiece measurement	<ul style="list-style-type: none"> TS 260 touch trigger probe with cable connection, or KT 130 simple touch trigger probe with cable connection
Tool measurement	<ul style="list-style-type: none"> TT 160 touch trigger probe
Software for PCs	<ul style="list-style-type: none"> RemoteAccess for remote diagnostics, monitoring, and operation CycleDesign for creating your own cycle structure TNCremo for data transfer—free of charge TNCremoPlus for data transfer with live-screen function

HEIDENHAIN

Mastering nanometer accuracy



HEIDENHAIN

DR. JOHANNES HEIDENHAIN GmbH
Dr.-Johannes-Heidenhain-Straße 5
83301 Traunreut, Germany
☎ +49 8669 31-0
☎ +49 8669 32-5061
info@heidenhain.de
www.heidenhain.com



HEIDENHAIN
worldwide