



HEIDENHAIN



Product Information

ERA 6000 Series

Angle Encoders without
Integral Bearing

January 2010

ERA 6000 Series



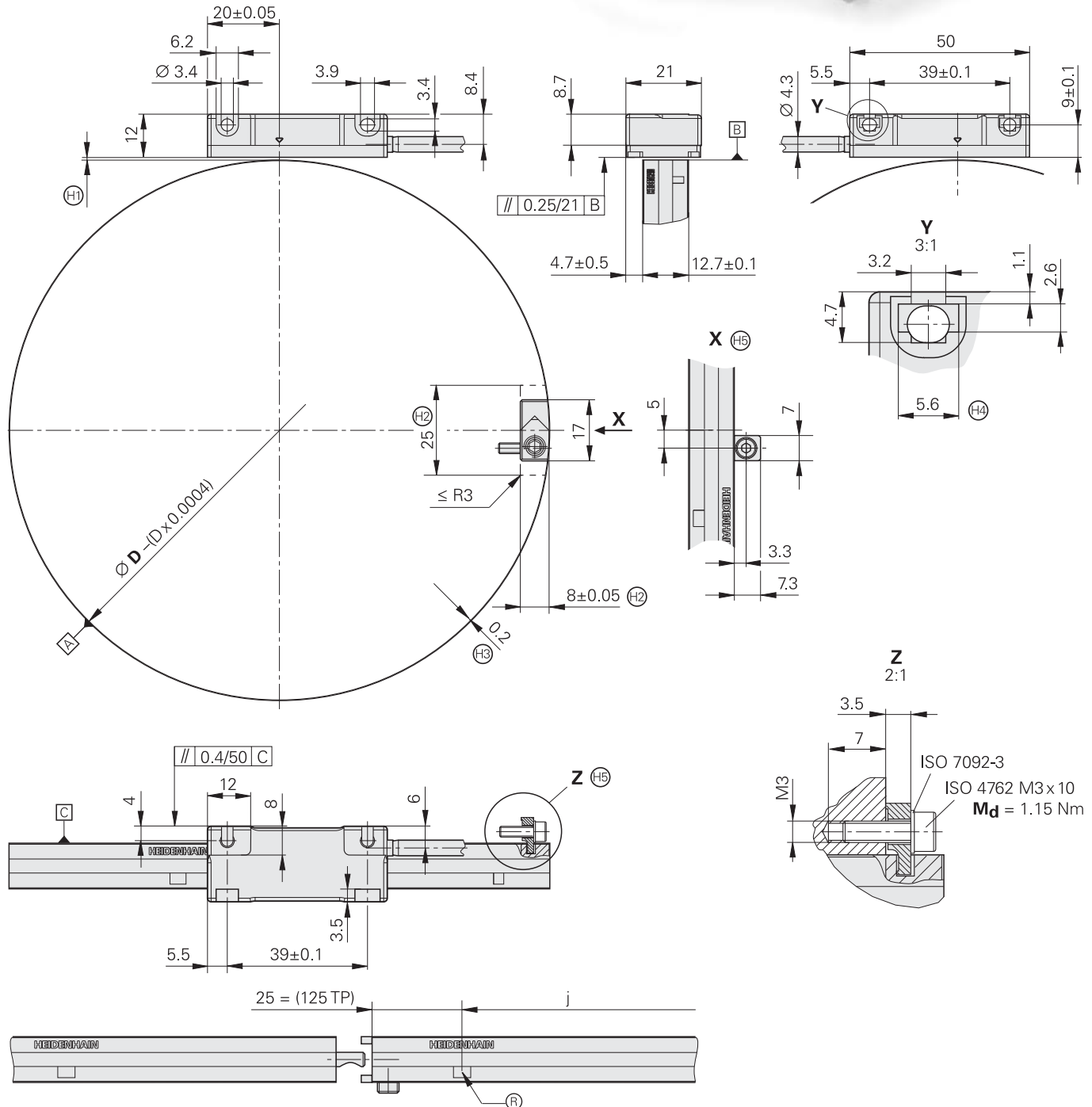





- Steel scale tape as graduation carrier
- For outside diameters
- Full-circle version with tensioning cleat







Dimensions in mm



 Tolerancing ISO 8015
 ISO 2768 - m H
 <math>< 6\text{ mm}</math>: $\pm 0.2\text{ mm}$

- D** = Shaft diameter
- TP = Grating period 200 μm
- j = Additional reference marks spaced every $n \times 100\text{ mm}$
-  = Bearing
-  = Reference mark
-  = $D < \varnothing 500 = 0.75 + 0.2 / -0.1$
-  = $D \geq \varnothing 500 = 0.75 + 0.4 / -0.2$
-  = Space for tensioning cleat
-  = Scale-tape thickness
-  = Hexagonal nut as per ISO 4032-M3 SW5.6
-  = Optional installation kit

Scanning head	ERA 6080		ERA 6070	
Incremental signals	 1 V _{PP}	 x 10	 x 50	 x 100
Integrated interpolation*	–	10-fold	50-fold	100-fold
Cutoff frequency –3 dB	≥ 90 kHz	–	–	–
Scanning frequency	–	≤ 50 kHz	≤ 25 kHz	≤ 12.5 kHz
Edge separation a	–	≥ 0.465 μs	≥ 0.175 μs	≥ 0.175 μs
Power supply	5 V ± 5 %			
Current consumption (without load)	< 110 mA	< 140 mA		
Electrical connection	Cable 3 m with D-sub connector (15-pin)			
Cable length	≤ 30 m (with HEIDENHAIN cable)			
Vibration 55 to 2000 Hz Shock 11 ms	≤ 200 m/s ² ≤ 500 m/s ²			
Operating temperature	0 °C to 50 °C			
Protection EN 60529	IP 00			
Weight	Scanning head Connector Cable	20 g (without cable) 32 g 30 g/m		

Scale tape	ERA 6000				
Measuring standard Coefficient of linear expansion	Steel scale tape $\alpha_{\text{therm}} \approx 10 \cdot 10^{-6} \text{ K}^{-1}$				
Scale-slot diameter*	159.07 mm	229.15 mm	318.34 mm	636.88 mm	1 146.54 mm
Line count ¹⁾	2500	3600	5000	10000	18000
Reference marks	Selectable every 100 mm				
System accuracy ²⁾	± 80"	± 60"	± 40"	± 20"	± 15"
Accuracy of the graduation ³⁾	± 30 μm per meter tape length				
Mech. permissible speed ⁴⁾	≤ 200 min ⁻¹	≤ 200 min ⁻¹	≤ 200 min ⁻¹	≤ 150 min ⁻¹	≤ 83 min ⁻¹
Permissible axial motion	≤ 0.5 mm (scale tape relative to scanning head)				
Permissible expansion coefficient of shaft	$\alpha_{\text{therm}} = 9 \cdot 10^{-6} \text{ K}^{-1}$ to $12 \cdot 10^{-6} \text{ K}^{-1}$				
Weight of scale tape	12 g + 20 g/m				

* Please select when ordering

¹⁾ Other line counts upon request (minimum 2350; maximum 18000)

²⁾ Before installation. Additional error caused by mounting inaccuracy and inaccuracy from the bearing of the drive shaft are not included.

³⁾ For other error, see *Measuring Accuracy* in the brochure *Angle Encoders without Integral Bearing*

⁴⁾ Higher speeds upon request

Accessory	ERA 6000	
Installation kit	Clamp for fixing the tensioning cleat	685303-01
Mounting aid	For easy adjustment of the scanning gap (when ordering please indicate mating diameter)	679213-xx

ERA 6006 Series



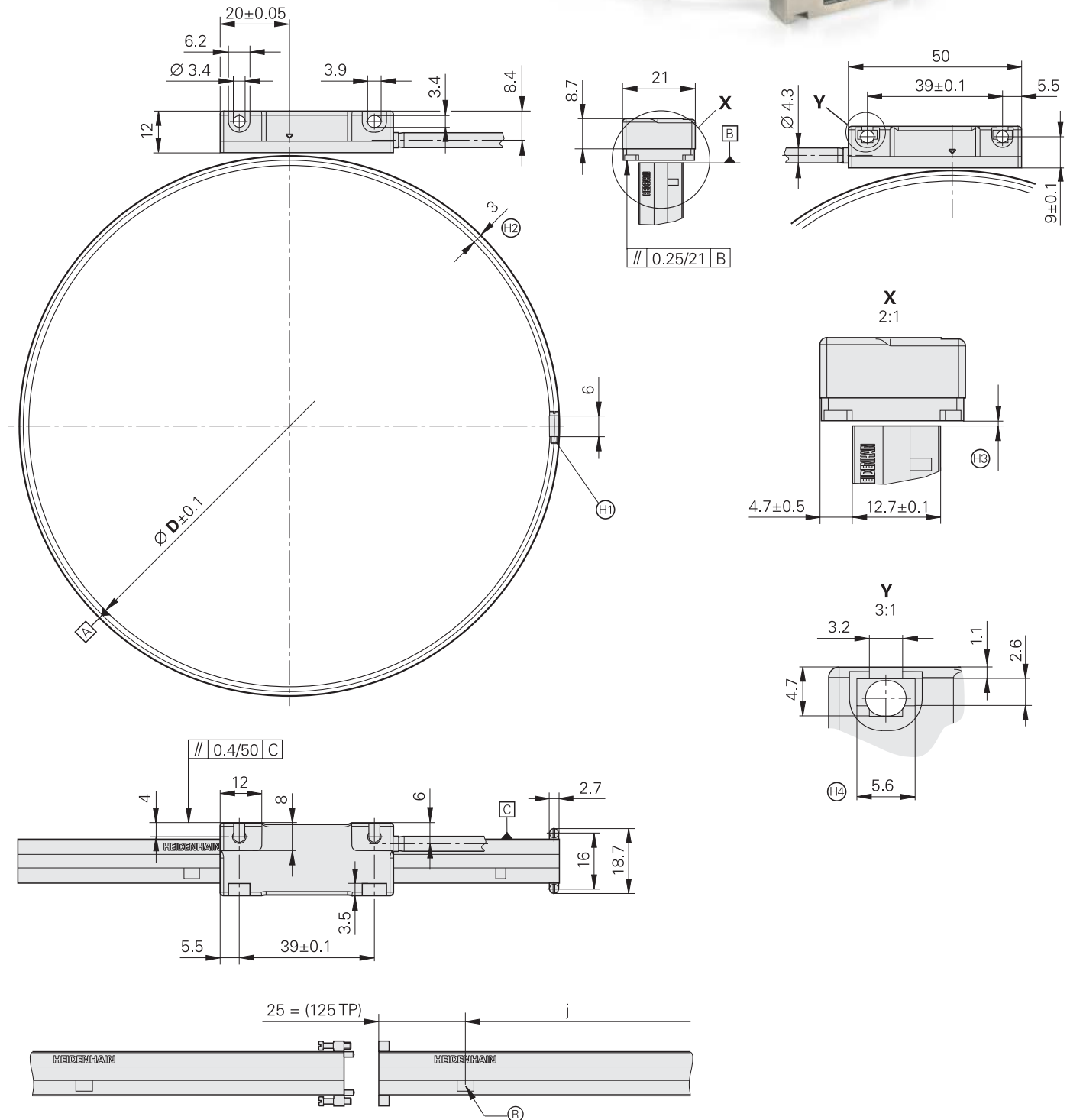

- Steel scale tape as graduation carrier
- For outside diameters
- Full-circle version with tensioning cleat
- Scale tape with elastic intermediate layer for large diameter tolerances and low surface quality



- D** = Shaft diameter
 TP = Grating period 200 µm
 j = Additional reference marks spaced every n x 100 mm
 A = Bearing
 H = Reference mark
 M = M2 tensioning screw
 S = Scale-tape thickness
 T = $D < \text{Ø } 500 = 0.75+0.2/-0.1$
 $D \geq \text{Ø } 500 = 0.75+0.4/-0.2$
 N = Hexagonal nut as per ISO 4032-M3 SW5.6

Dimensions in mm

Tolerancing ISO 8015
 ISO 2768 - m H
 < 6 mm: ±0.2 mm

Scanning head	ERA 6080		ERA 6070		
Incremental signals	 1 V _{PP}	 x 10	 x 50	 x 100	
Integrated interpolation*	–	10-fold	50-fold	100-fold	
Cutoff frequency –3 dB	≥ 90 kHz	–	–	–	
Scanning frequency	–	≤ 50 kHz	≤ 25 kHz	≤ 12.5 kHz	
Edge separation a	–	≥ 0.465 μs	≥ 0.175 μs	≥ 0.175 μs	
Power supply	5 V ± 5 %				
Current consumption (without load)	< 110 mA		< 140 mA		
Electrical connection	Cable 3 m with D-sub connector (15-pin)				
Cable length	≤ 30 m (with HEIDENHAIN cable)				
Vibration 55 to 2000 Hz Shock 11 ms	≤ 200 m/s ² ≤ 500 m/s ²				
Operating temperature	0 °C to 50 °C				
Protection EN 60529	IP 00				
Weight	Scanning head Connector Cable	20 g (without cable) 32 g 30 g/m			

Scale tape	ERA 6006				
Measuring standard Expansion coefficient	Steel scale tape $\alpha_{\text{therm}} \approx 10 \cdot 10^{-6} \text{ K}^{-1}$				
Scale-slot diameter*	153.35 mm	223.38 mm	312.51 mm	630.82 mm	1 140.12 mm
Line count ¹⁾	2500	3600	5000	10000	18000
Reference marks	Selectable every 100 mm				
System accuracy ²⁾	± 350"	± 250"	± 200"	± 100"	± 50"
Accuracy of the graduation ³⁾	± 30 μm per meter tape length				
Mech. permissible speed ⁴⁾	≤ 200 min ⁻¹	≤ 200 min ⁻¹	≤ 200 min ⁻¹	≤ 150 min ⁻¹	≤ 83 min ⁻¹
Permissible axial motion	≤ 0.5 mm (scale tape relative to scanning head)				
Permissible thermal diameter change between shaft and scale tape	≤ ± 0.2 mm				
Weight of scale tape	2.5 g + 45 g/m				

* Please select when ordering

¹⁾ Other line counts upon request (minimum 2350; maximum 18000)

²⁾ Before installation. Additional error caused by mounting inaccuracy and inaccuracy from the bearing of the drive shaft are not included.

³⁾ For other error, see *Measuring Accuracy* in the brochure *Angle Encoders without Integral Bearing*

⁴⁾ Higher speeds upon request

Accessory	ERA 6006	
Mounting aid	For easy adjustment of the scanning gap (when ordering please indicate mating diameter)	679213-xx

ERA 6002 Series



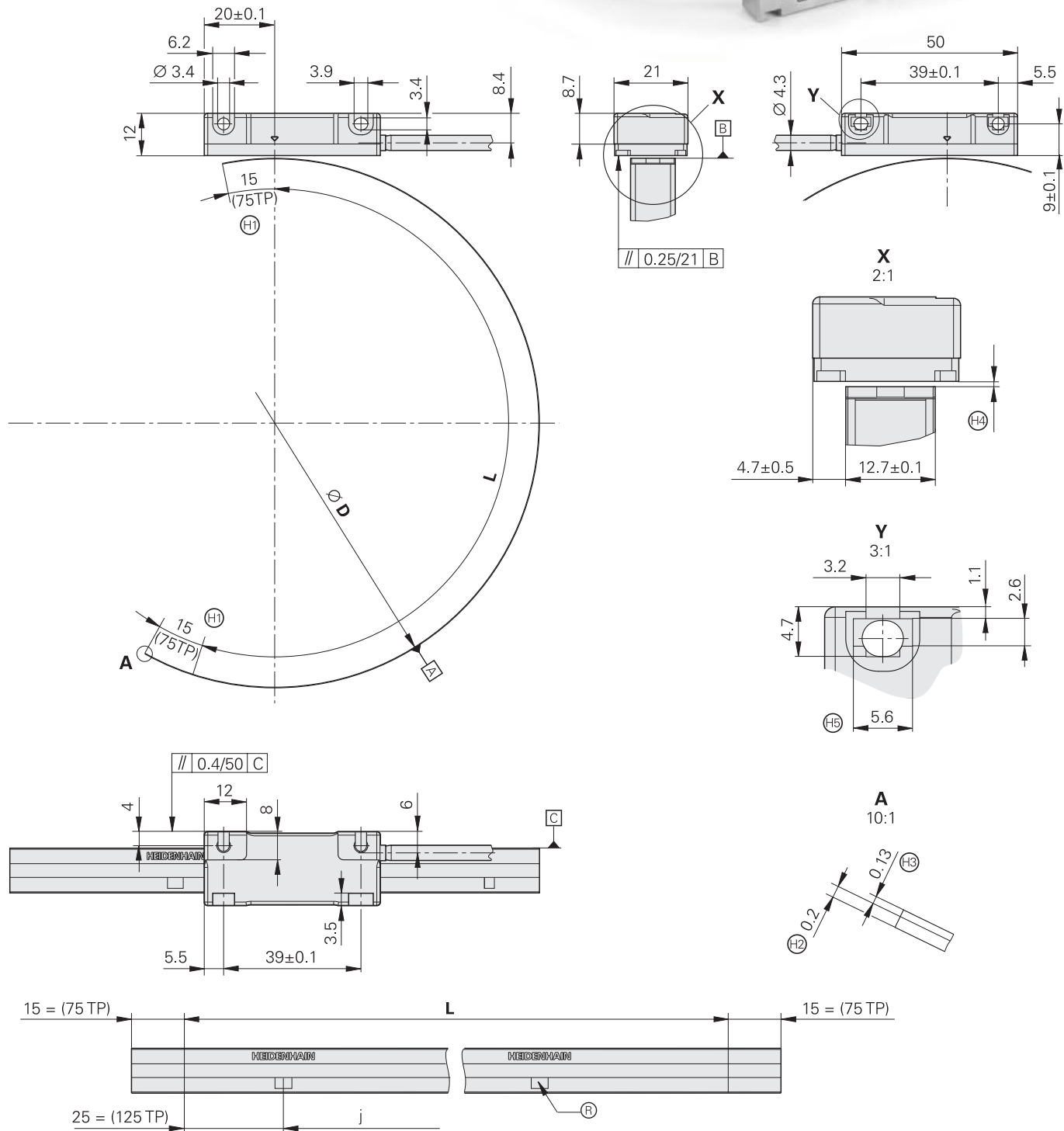

- Steel scale tape as graduation carrier
- For outside diameters
- Segment version
- Simple scale tape fastening by adhesive



- D** = Shaft diameter
- L** = Measuring range
- TP = Grating period $200 \mu\text{m}$
- j** = Additional reference marks spaced every $n \times 100 \text{ mm}$
- H1 = Bearing
- H2 = Reference mark
- H3 = Allowance
- H4 = Steel scale tape
- H5 = Adhesive tape
- H6 = $D < \varnothing 500 = 0.75 + 0.2 / -0.1$
 $D \geq \varnothing 500 = 0.75 + 0.4 / -0.2$
- H7 = Hexagonal nut as per ISO 4032-M3 SW5.6

Dimensions in mm

Tolerancing ISO 8015
ISO 2768 - m H
< 6 mm: $\pm 0.2 \text{ mm}$

Scanning head	ERA 6080	ERA 6070		
Incremental signals	 1 V _{PP}	 TTL x 10	 TTL x 50	 TTL x 100
Integrated interpolation*	–	10-fold	50-fold	100-fold
Cutoff frequency –3 dB	≥ 90 kHz	–	–	–
Scanning frequency	–	≤ 50 kHz	≤ 25 kHz	≤ 12.5 kHz
Edge separation a	–	≥ 0.465 μs	≥ 0.175 μs	≥ 0.175 μs
Power supply	5 V ± 5 %			
Current consumption (without load)	< 110 mA	< 140 mA		
Electrical connection	Cable 3 m with D-sub connector (15-pin)			
Cable length	≤ 30 m (with HEIDENHAIN cable)			
Vibration 55 to 2000 Hz Shock 11 ms	≤ 200 m/s ² ≤ 500 m/s ²			
Operating temperature	0 °C to 50 °C			
Protection EN 60529	IP 00			
Weight	Scanning head Connector Cable	20 g (without cable) 32 g 30 g/m		

Scale tape	ERA 6002
Measuring standard Expansion coefficient	Steel scale tape $\alpha_{\text{therm}} \approx 10 \cdot 10^{-6} \text{ K}^{-1}$
Scale-slot diameter*	≥ 150 mm ¹⁾
Line count*	Min. 300, max. 50 000 (5 lines/mm)
Reference marks	Selectable every 100 mm
Accuracy of the graduation ²⁾	± 30 μm per meter tape length
Permissible axial motion	≤ 0.5 mm (scale tape relative to scanning head)
Weight of scale tape	20 g/m

* Please select when ordering



¹⁾ For mating diameters < 400 the scale tape is pre-bent

²⁾ For other error, see *Measuring Accuracy* in the brochure *Angle Encoders without Integral Bearing*

Accessory	ERA 6002	
Mounting aid	For easy adjustment of the scanning gap (when ordering please indicate mating diameter)	679213-xx
Roller	For applying the scale tape	276885-01





Electrical Connection

Pin Layout

15-pin D-sub connector, male															
Power supply		Incremental signals							Other signals						
	2	4	1	9	3	11	14	7	13	10	12	15	5	6	8
	U_P	0V	U_{a1}	\overline{U}_{a1}	U_{a2}	\overline{U}_{a2}	U_{a0}	\overline{U}_{a0}	\overline{U}_{aS}	/	/	/	/	/	/
			A+	A-	B+	B-	R+	R-	/						
	Brown/ Green	White/ Green	Brown	Green	Gray	Pink	Red	Black	Violet	White	Blue	Yellow	/	/	/

Shield on housing; U_P = Power supply voltage
Vacant pins or wires must not be used.

Connecting Cable

PUR connecting cable [6(2 x 0.19 mm ²)]			
PUR connecting cable [4(2 x 0.14 mm ²) + (4 x 0.5 mm ²)]		Ø 8 mm	Ø 6 mm ¹⁾
Complete with D-sub connector (female), 15-pin, and M23 connector (male), 12-pin		331 693-xx	355 215-xx
With one D-sub connector (female), 15-pin		332 433-xx	355 209-xx
Complete with D-sub connector (female) and D-sub connector (male), both 15-pin		335 074-xx	355 186-xx
Complete with D-sub connector (female) and D-sub connector (female), both 15-pin Assignment for IK 220		335 077-xx	349 687-xx
Cable only		244 957-01	291 639-01

¹⁾ Cable length for Ø 6 mm max. 9 m

HEIDENHAIN

DR. JOHANNES HEIDENHAIN GmbH

Dr.-Johannes-Heidenhain-Straße 5

83301 Traunreut, Germany

☎ +49 8669 31-0

FAX +49 8669 5061

E-mail: info@heidenhain.de

www.heidenhain.de

For more information

- Brochure: *Angle Encoders without Integral Bearing*